

# RapID™ Platform - EtherCAT Network Interface

2-Port Connectivity Solution for Slave Devices



**The RapID Platform Network Interface is a complete, pre-tested solution that manages the industrial protocol and network traffic for a host processor**

The *Network Interface* module or embedded design contains everything needed to participate in an EtherCAT network including the communications controller, protocol stack, Flash, RAM, EtherCAT slave controller, and PHYs. A host processor connects to the Network Interface via a UART or 16-bit Parallel Interface. At the software layer, the host connects to a "Unified Interface" so **other protocols can be used without changing the host processor software**. The Network Interface will pass EtherCAT Conformance Testing so your field device will operate problem-free in any EtherCAT network.

## Easy Hardware and Software Integration

The *Network Interface* can be integrated into a design as either a module or an embedded design. As a module, the *Network Interface* plugs into a board using standard 2.54 mm pitch through-hole pins. When designing-in the module, hardware integration is as easy as connecting Power/Ground/Reset and interfacing the Host to the UART or 16-bit Parallel interface.

As an embedded design, the *Network Interface* hardware design can be integrated directly using the schematics provided. Also provided are the Bill of Materials and example layouts to minimize the hardware design effort. Software for the embedded design is provided as firmware that is downloaded to the flash. Whether using the *Network Interface* as a module or an embedded design, **no software development is required and there are no license fees or royalties**.

Software integration with a Host is also easy. Messages passed between the Host and *Network Interface* follow a "Unified Interface" definition. A simple-to-use, Innovasic-supplied, **PC-based tool configures the**

***Network Interface***, so the Host only passes I/O data between it and the *Network Interface*. From this tool, it is also easy to specify how I/O data will be passed to the EtherCAT controller using the ESI file. Since the Host is only passing I/O data, the Host software does not have to change if EtherCAT network parameters change or if another Industrial Ethernet protocol is used. There is also a "sockets" interface that supports direct Ethernet communication via the Ethernet over EtherCAT (EoE) service. Example C-code is provided to minimize the software effort for the Host / Network Interface communication.

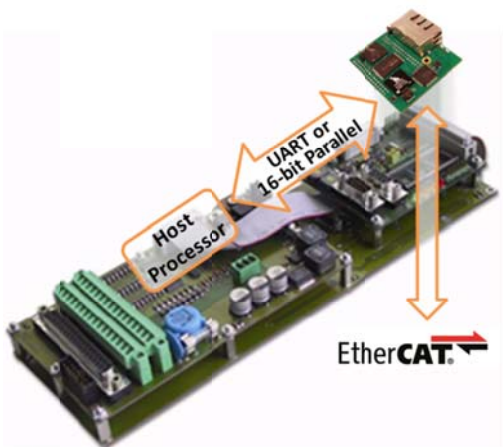
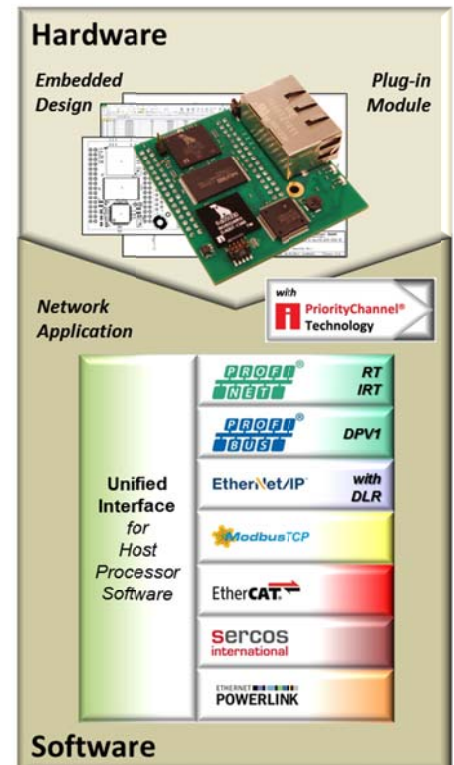

# RapID™ Platform - EtherCAT Network Interface

2-Port Connectivity Solution for Slave Devices



## Reliable, Flexible Network Integration

The EtherCAT Slave Controller (ESC) on the *Network Interface* contains 8 SyncManager entities, 8 FMMU entities, and resources to utilize Distributed Clocks. The *Network Interface* makes use of these features to support the Modular Device Profile (MDP). The Modular Device Profile allows easy definition of I/O modules that represent the size and type of process data for an application. In this way, the *Network Interface* is easily customized to represent all of the data an application produces or consumes via EtherCAT. In addition, all of the parameters defined in an MDP profile are available for access via the CAN over Ethernet (CoE) mailbox protocol, adding flexibility to the end product. The *Network Interface* also provides an embedded webserver so users can view network parameters and I/O data via customizable webserver content using the Ethernet over EtherCAT (EoE) mailbox protocol.

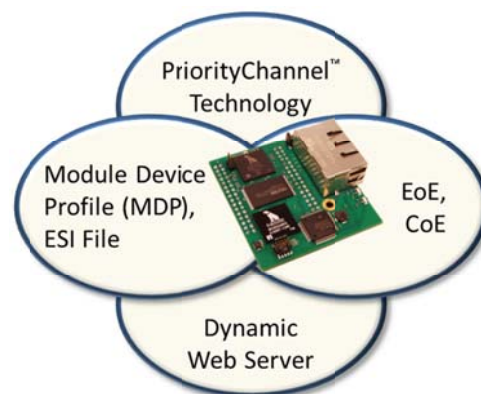

At the physical layer, the *Network Interface* PHYs meet the EtherCAT system requirements for latency and jitter. The on-board EtherCAT slave controller, which is implemented by Innovasic's Real-time Ethernet, Multi-protocol (REM) switch, has a bridge delay of only 0.9  $\mu$ s.

## Fast Evaluation and Development

The *RapID Platform Network Interface* Evaluation Kit provides a quick assessment for interfacing a Host to the module. An application example is provided in order to demonstrate end-to-end, Host-to-Network Interface-to-Controller communication. Simply connect the Host development board to the *Network Interface* evaluation board via the UART or 16-bit Parallel interface. Once Host-side communication is established, EtherCAT communication can be evaluated using a PLC or Controller simulator. The communication path between Host and EtherCAT controller can be completely verified before integrating the module into your field device hardware.



RapID Platform EtherCAT Network Interface	
Parameter	Details
Part Number	RapID-NI V2008, RapID-NI V2108
Host Processor	Any CPU or DSP
Host Processor Interfaces	UART (115.2 kBaud) 16-bit Parallel (up to 12.5 Mbps)
Network Interface	Data Transport: IEEE 802.3 Data Rate: 100 Mbps Ports: 2
Temperature	-40C to +85C
Power Supply	Voltage: 3.3 VDC Power consumption: 1.6W
EtherCAT	Cyclic Input Data: 1440 bytes Cyclic Output Data: 1440 bytes Cycle time: 500 $\mu$ s (min) SyncManager Entities: 8 FMMU Entities: 8 Distributed Clock Support MDP, EoE, CoE
Compliance	RoHS, CE, ETG